

S45 TRAILER MOUNTED CONCRETE PUMP

The S45 trailer mounted concrete pump has been specifically engineered to increase your productivity and most importantly, your profitability to ensure Jacon is the right partner for you.

The S45 trailer mounted concrete pump is a small to medium size pump. With an output of up to 45m³/hr, a vertical reach of 100 metres and a horizontal reach of up to 350 metres, this Jacon pump is capable of working in the most versatile jobsites.

Containing the superbly engineered “S” valve, the S45 trailer mounted concrete pump is capable of handling extremely harsh mixes as well as low slump concrete. This compact and robust unit can be utilised for many applications within the civil mining industry such as footings, concrete slabs, blockfilling, footpaths and driveways.

The option to be set up as a shotcrete machine provides even greater versatility and therefore increased service applications such as earth stabilisation and retaining walls.

**ROBUST AND
RELIABLE, THIS
MACHINE IS PURPOSE
BUILT FOR TROUBLE
FREE OPERATION**



DIMENSIONS

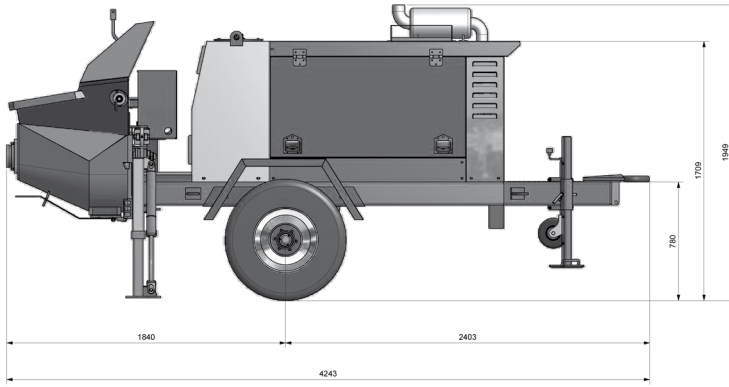

SIDE VIEW

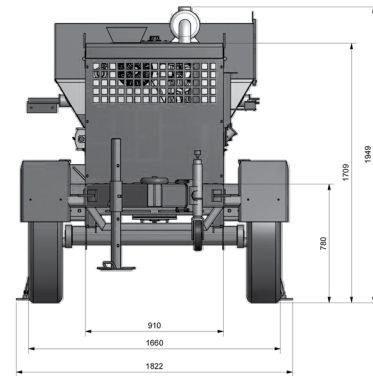

FRONT VIEW

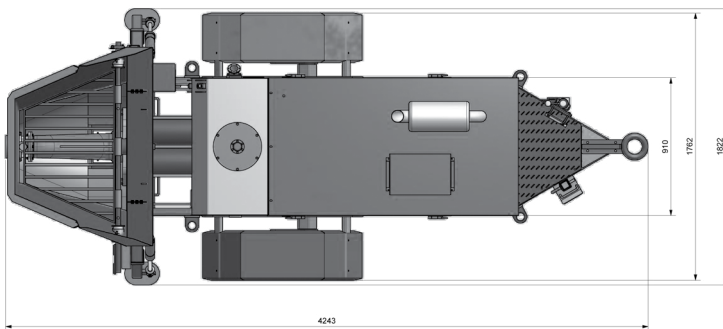

TOP VIEW

SPECIFICATIONS

Pump	160mm hardchromed concrete cylinders with 900mm stroke. Swinger tube model with dual reciprocating pistons
Power Unit	4 cylinder turbo charged, Deutz diesel engine, 73KW @ 2300 RPM
Hydraulic Pressure Max	350 Bar
Rated Output	45 Cubic Metres / Hour
Line Pressure Max	80 Bar
Vertical Reach	100 Metres
Horizontal Reach	350 Metres

Aggregate size: * Up to 30mm that falls within the accepted grading curve for pump mix.

Note: * Performance may vary due to material mix or line set up.
* Maximum vertical and horizontal reach cannot be achieved simultaneously.

FEATURES

- Dual circuit hydraulic system for smooth positive swinger tube action
- Hydraulic pilot system with Electric over-ride
- Fully automatic stroke adjustment
- Variable Displacement Piston Pump
- Heavy duty suspension axle
- Lifting Lugs
- Single Channel Cordless remote control
- Hydraulic Jack Legs on rear

OPTIONAL ADDITIONS

- Shotcrete ready capabilities
- Road Readiness Kit
- 4 Channel Remote control system
- Standard Pipeline Kit
- Blockfill Kit
- Hopper Remixer
- Chemical Pump with Flow Meter
- Spraying Kit