

# ***S30 TRAILER MOUNTED CONCRETE PUMP***

*The S30 trailer mounted concrete pump has been specifically engineered to increase your productivity and most importantly, your profitability to ensure Jacon is the right partner for you.*

The S30 trailer mounted concrete pump is a small to medium size pump. With an output of up to 30m<sup>3</sup>/hr, a vertical reach of 80 metres and a horizontal reach of up to 250 metres, this Jacon pump is capable of working in the most versatile jobsites.

Containing the superbly engineered “S” valve, the S30 trailer mounted concrete pump is capable of handling extremely harsh mixes as well as low slump concrete. This compact and robust unit can be utilised for many applications within the civil mining industry such as footings, concrete slabs, blockfilling, footpaths and driveways.

The option to be set up as a shotcrete machine provides even greater versatility and therefore increased service applications such as earth stabilisation and retaining walls.

**ROBUST AND  
RELIABLE, THIS  
MACHINE IS PURPOSE  
BUILT FOR TROUBLE  
FREE OPERATION**



Specifications subject to change without notice | For further equipment details contact [info@jacon.com.au](mailto:info@jacon.com.au)

## DIMENSIONS

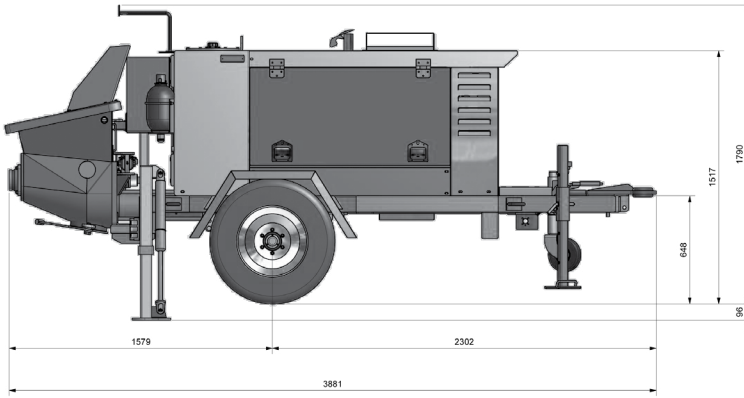

SIDE VIEW

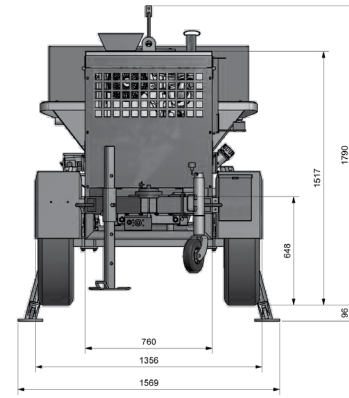

FRONT VIEW

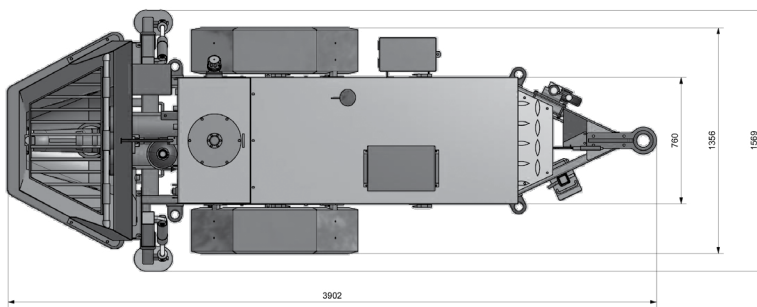

TOP VIEW

## SPECIFICATIONS

Pump	125mm hard chromed concrete cylinders with 915mm stroke. S-Valve 125mm – 100mm, swingtube design concrete transfer valve in hopper with 100mm Outlet
Power Unit	4 Cylinder Deutz Engine 55KW @ 2200RPM
Hydraulic Pressure Max	250 Bar
Rated Output	0-30 Cubic Metres / Hour
Line Pressure Max	70 Bar
Vertical Reach	80 Metres
Horizontal Reach	250 Metres

Aggregate Size: \*Up to 20mm that falls within the accepted grading curve for pump mix.

Note: \*Performance may vary due to material mix or line set up.

\*Maximum vertical and horizontal reach cannot be achieved simultaneously.

## FEATURES

- Hydraulic Pilot System with Electric Over-ride
- Variable Displacement Piston Pump
- Spot Light on Hopper
- Single Channel Cordless Remote Control
- Heavy Duty Suspension Axle
- Hydraulic Jack Legs on rear
- Lifting Lugs

## OPTIONAL ADDITIONS

- Shotcrete Ready Capability
- Road Readiness Kit
- Air Blow Out System
- High Pressure Gurney (Hydraulic Driven w/o Water Tank)
- 4 Channel Remote Control System
- Hopper Remixer
- Chemical Pump with Flow Meter
- Standard Pipeline Kit
- Spraying Kit